

**TURCK**

Your Global Automation Partner

CMVT-M8T...-...

# Condition Monitoring Sensors

Instructions for Use

# Contents

<b>1</b>	<b>About these instructions .....</b>	<b>4</b>
1.1	Target groups .....	4
1.2	Explanation of symbols .....	4
1.3	Other documents .....	4
1.4	Feedback about these instructions .....	4
<b>2</b>	<b>Notes on the product .....</b>	<b>5</b>
2.1	Product identification .....	5
2.2	Scope of delivery.....	5
2.3	TURCK service .....	5
<b>3</b>	<b>For your safety .....</b>	<b>6</b>
3.1	Intended use .....	6
3.2	Obvious misuse .....	6
3.3	General safety instructions .....	6
3.4	Notes on the UL approval.....	6
<b>4</b>	<b>Product description .....</b>	<b>7</b>
4.1	Device overview .....	7
4.2	Properties and characteristics .....	7
4.3	Functional principle .....	7
4.4	Functions and operating modes .....	9
4.4.1	IO-Link mode.....	9
4.4.2	SIO mode (standard I/O mode) .....	9
4.4.3	Temperature measurement .....	9
4.4.4	Limit counter.....	9
4.4.5	Output function — analog output .....	9
4.4.6	Output function — switching output.....	10
4.5	Technical accessories .....	11
4.5.1	Mounting accessories .....	13
<b>5</b>	<b>Installing .....</b>	<b>16</b>
<b>6</b>	<b>Connection .....</b>	<b>17</b>
6.1	Wiring diagrams.....	17
<b>7</b>	<b>Commissioning .....</b>	<b>18</b>
<b>8</b>	<b>Operation.....</b>	<b>19</b>
<b>9</b>	<b>Setting .....</b>	<b>20</b>
9.1	Setting switching signals via Measurement Data Channels (MDC) .....	20
9.2	Setting the limit counter and timer for alarms .....	20
9.3	Frequency ranges .....	20
9.4	Setting and visualization with the TURCK Vibration Monitor.....	20
9.4.1	IO-Link master — opening the web server .....	21
9.4.2	Reading in IODD in the web server .....	22
9.4.3	TURCK Vibration Monitor — overview .....	23
9.5	Setting via FDT/IODD .....	24
<b>10</b>	<b>Troubleshooting.....</b>	<b>25</b>
<b>11</b>	<b>Maintenance .....</b>	<b>26</b>

- 12 Repair ..... 26
  - 12.1 Returning devices ..... 26
- 13 Disposal..... 27
- 14 Technical data..... 28
  - 14.1 CMVT-M8T...-LI2IOL-H1141 ..... 28
  - 14.2 CMVT-M8T...-LI2...-H1141 ..... 29
- 15 TURCK branches — contact data ..... 30

# 1 About these instructions

These instructions describe the setup, functions and use of the product and help you to operate the product according to its intended purpose. Read these instructions carefully before using the product. This will prevent the risk of personal injury and damage to property. Keep these instructions safe during the service life of the product. If the product is passed on, pass on these instructions as well.

## 1.1 Target groups

These instructions are aimed at qualified personal and must be carefully read by anyone mounting, commissioning, operating, maintaining, dismantling or disposing of the device.

## 1.2 Explanation of symbols

The following symbols are used in these instructions:



### **DANGER**

DANGER indicates a hazardous situation with a high level of risk, which, if not avoided, will result in death or serious injury.



### **WARNING**

WARNING indicates a hazardous situation with a medium level of risk, which, if not avoided, will result in death or serious injury.



### **CAUTION**

CAUTION indicates a hazardous situation with a medium level of risk, which, if not avoided, will result in moderate or minor injury.



### **NOTICE**

CAUTION indicates a situation which, if not avoided, may cause damage to property.



### **NOTE**

NOTE indicates tips, recommendations and important information about special action steps and issues. The notes simplify your work and help you to avoid additional work.



### **MANDATORY ACTION**

This symbol denotes actions that the user must carry out.



### **RESULT OF ACTION**

This symbol denotes the relevant results of an action.

## 1.3 Other documents

Besides this document, the following material can be found on the Internet at [www.turck.com](http://www.turck.com):

- Data sheet
- Declarations of conformity (current version)
- IODD
- Approvals

## 1.4 Feedback about these instructions

We make every effort to ensure that these instructions are as informative and as clear as possible. If you have any suggestions for improving the design or if some information is missing in the document, please send your suggestions to [techdoc@turck.com](mailto:techdoc@turck.com).

## 2 Notes on the product

### 2.1 Product identification

These instructions apply to the following condition monitoring sensors:

**CM VT - M8TA1X - LI2IOL - H1 1 4 1**

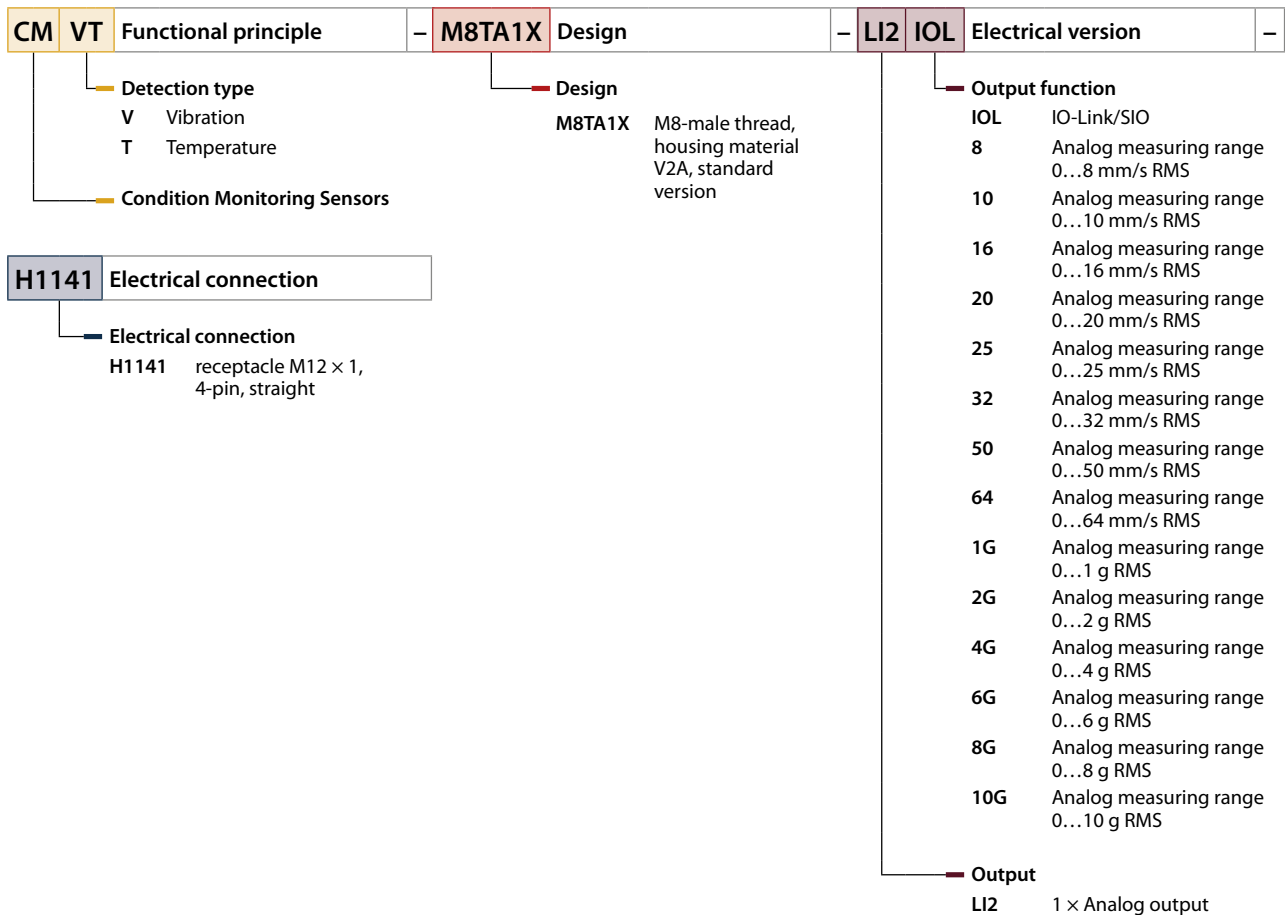

### 2.2 Scope of delivery

The scope of delivery includes:

- Condition monitoring sensor CMVT-M8T...-LI2...-H1141

### 2.3 TURCK service

TURCK supports you in your projects — from the initial analysis right through to the commissioning of your application. At [www.turck.com](http://www.turck.com), you will find software tools for programming, configuring or commissioning, as well as data sheets and CAD files in many export formats.

For the contact details of our branches worldwide, please see page [▶ 30].

## 3 For your safety

The product is designed according to state of the art technology. Residual hazards, however, still exist. Observe the following safety instructions and warnings in order to prevent danger to persons and property. TURCK accepts no liability for damage caused by failure to observe these safety instructions.

### 3.1 Intended use

The condition monitoring sensors in the CMVT-M8T... product series monitor machine vibration and temperature.

The vibration values are output via IO-Link or an analog output, depending on the device variant. In addition, devices with a switching output indicate the exceeding of switching points. The devices are suitable for machine status monitoring (condition monitoring).

The device must only be used as described in these instructions. Any other use is not in accordance with the intended use. TURCK accepts no liability for any resulting damage.

### 3.2 Obvious misuse

- The devices are not safety components and must not be used for personal protection.

### 3.3 General safety instructions

- The device meets the EMC requirements for the industrial areas. When used in residential areas, take measures to prevent radio frequency interference.
- The device must only be fitted, installed, operated, parameterized and maintained by trained and qualified personnel.
- Only use the device in compliance with the applicable national and international regulations, standards and laws.
- Only operate the device within the limits stated in the technical specifications.

### 3.4 Notes on the UL approval

- Devices must be protected by fuses, circuit breakers, overheat protection, impedance-limiting circuits or similar means to provide protection against excessive power output in the event of a failure in the device. The protection must be applied to the supply and switching cables.
- A suitable circuit breaker for 30 V/3 A according to UL Standard 489/CSA Standard (C22.2) No. 5/IEC 60947-2 must be installed near the device.
- A suitable fuse according to UL Standard 248/CSA Standard (C22.2) No. 248/IEC 60127 must be installed near the device. The fuse must have the tripping characteristic of slow-blow "T."

## 4 Product description

### 4.1 Device overview

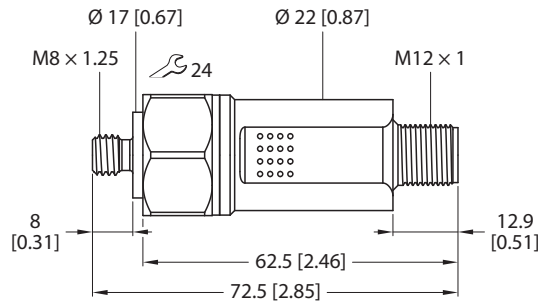

mm [Inch]

Fig. 1: Dimensions of CMVT-M8T...

### 4.2 Properties and characteristics

- Acceleration and velocity output as:
  - Vibration velocity (0.01 mm/s, rms)
  - Vibration acceleration (0.01 g, rms)
  - Vibration acceleration (0.01 g, peak)
- Temperature detection from -40...+80 °C, accuracy ±10 %
- Protection class IP66/IP67
- CMVT...-LI2IOL...: 1 switching output or IO-Link and 1 switching output or 1 analog output 4...20 mA
- CMVT...-LI2...: 1 analog output 4...20 mA
- Communication via IO-Link: measured values, switching state, device status, error state
- Maintenance requests via limit counter and timer for instances where thresholds are exceeded
- Parameterizable frequency range

### 4.3 Functional principle

The condition monitoring sensors measure the vibration velocity and vibration acceleration of the absolute bearing vibration via an axis to determine the machine status. The monitoring of vibrations and oscillations makes it possible to detect deviations early on and take counter-measures. The process value is transferred to the controller via IO-Link for monitoring.

Device variants with a switching output can also indicate that switching points have been exceeded. The analog output displays vibration velocity, acceleration and temperature above 4...20 mA.

### Operating range of vibration monitoring

The operating range can be derived from the maximum acceleration. The operating range is independent of the measuring range.

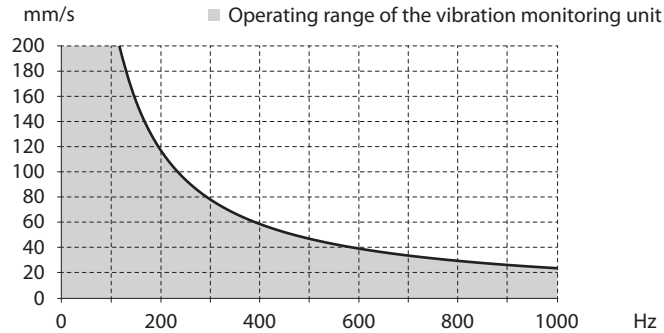

The maximum measurable vibration velocity with  $\pm 15$  g across all frequencies is calculated using the following formula:

$$v_{max} = \int a_{max}$$

The sinusoidal vibration is calculated using the following formula:

$$v_{max} = \frac{a_{max}}{2\pi f}$$

### Typical frequency response

The frequency response of 10...1000 Hz is illustrated in the following diagram:

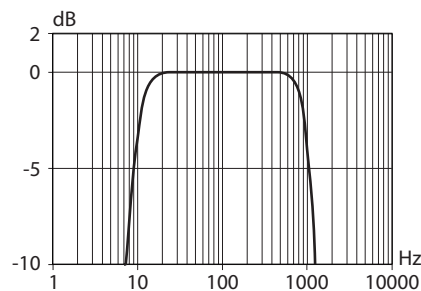

## 4.4 Functions and operating modes

Type	Outputs
CMVT...LI2IOL...	1 switching output or IO-Link and 1 switching output or 1 analog output
CMVT...LI2...	1 analog output

Depending on the version, the devices have an IO-Link mode and an SIO mode. In IO-Link mode, the devices can be configured using an IO-Link master. In SIO mode, only the switching state of the outputs is transferred. A Single Point Mode or Window Mode can be configured via the switching outputs. In Single Point Mode, a limit value is set at which the selected switching output changes its switching state. In Window Mode, a lower and an upper window limit are set. Outside the window, the selected switching output changes its switching state.

### 4.4.1 IO-Link mode

In order to operate in IO-Link mode, the device must be connected to an IO-Link master. When the port is configured in IO-Link mode, bidirectional IO-Link communication takes place between the IO-Link master and the device. To make this possible, the device is integrated via an IO-Link master at the control level. First the communication parameters are exchanged, and then the cyclic data exchange of process data (objects) starts.

### 4.4.2 SIO mode (standard I/O mode)

In standard I/O mode no IO-Link communication takes place between the device and the master. The device only transfers the switching state of its binary outputs and can also be run via a fieldbus device or controller with digital PNP or NPN inputs. An IO-Link master is not required for operation.

The device parameters can be set via IO-Link and then operated at the digital inputs with the appropriate settings in SIO mode. Not all functions and properties of the device can be used in SIO mode.

### 4.4.3 Temperature measurement

The condition monitoring sensors can output the temperature via IO-Link. The detection range is  $-40 \dots +80 \text{ }^\circ\text{C}$  at a resolution of  $1 \text{ }^\circ\text{C}$ . The accuracy is  $\pm 10 \%$ .

### 4.4.4 Limit counter

The limit counter reports instances where measured values are exceeded, as well as the duration for which the values are exceeded and a total of the amounts by which these values are exceeded. Alarms, e.g. for maintenance intervals, can be configured for instances where limit values are exceeded.

### 4.4.5 Output function — analog output

Depending on the configured measured variable, the maximum measured value at the analog output can be scaled via IO-Link.

- Adjustable vibration velocity RMS  $\leq 128 \text{ mm/s}$ : The analog output supplies 4 mA at 0 mm/s and 20 mA at the set maximum value.
- Adjustable vibration acceleration RMS  $\leq 10 \text{ g}$ : The analog output supplies 4 mA at 0 g and 20 mA at the set maximum value.
- Adjustable vibration acceleration peak  $\leq 14 \text{ g}$ : The analog output supplies 4 mA at 0 g and 20 mA at the set maximum value.
- Adjustable min. and max. measuring range for temperature  $-40 \dots 80 \text{ }^\circ\text{C}$ : The analog output supplies 4 mA at  $-40 \text{ }^\circ\text{C}$  and 20 mA at the set maximum value.

#### 4.4.6 Output function — switching output

A Single Point Mode or Window Mode for the switching outputs can be configured via IO-Link.

The switching logic can be inverted. The following examples apply to the **HIGH** (0 → 1) switching logic.

##### Single Point Mode

In Single Point Mode, the switching behavior is defined via a SP1 limit value and a hysteresis. The hysteresis is 2 % and can only be freely configured for temperature values (0...20 K). The output changes its switching state at limit value SP1.

If the process value increases, the switching output is inactive as long as the process value is between the start of the detection range and the SP1 limit value. If the process value increases above the SP1 limit value, the switching output becomes active.

If the process value decreases, the switching output is active as long as the process value is between the end of the detection range and the SP1 limit minus the set hysteresis (SP1-Hyst). If the process value decreases below the limit value (SP1-Hyst), the switching output becomes inactive.

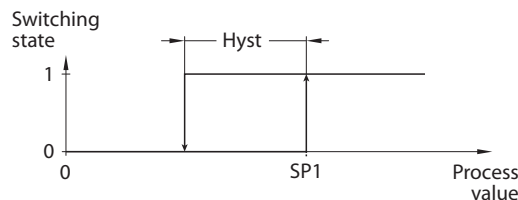

Fig. 2: Single Point Mode

##### Window Mode

In Window Mode, an upper and a lower window limit are set for the switching output. A hysteresis can be set for the window limits SP1 and SP2. The hysteresis is 2 % and can only be freely configured for temperature values (0...20 K). The switching window must be within the detection range.

If the process value increases, the switching output is inactive as long as the process value is between the start of the detection range and the window limit SP2. The switching output remains active until the process value increases above the window limit SP1 plus the hysteresis (SP1+Hyst). If the process value increases above (SP1+Hyst), the switching output becomes inactive again.

If the process value decreases, the switching output is inactive as long as the process value is between the end of the detection range and the window limit SP1. The switching output remains active until the process value decreases below the window limit SP2 minus the hysteresis (SP2-Hyst). If the process value decreases below (SP2-Hyst), the switching output becomes inactive again.

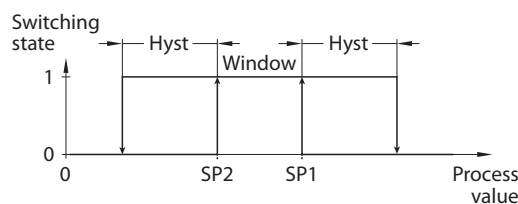

Fig. 3: Window Mode

## 4.5 Technical accessories

Dimension drawing	Type	ID	Description
	GUARD-QR20	100027185	Protective housing for QR20 inclination sensors to protect against mechanical impact; material: stainless steel
	USB-2-IOL-0002	6825482	IO-Link adapter V1.1 with integrated USB interface
	FEN20-4IOL	6814140	Compact multiprotocol I/O module for Ethernet, 4 IO-Link master channels, protection type IP20
	TBEN-L4-8IOL	6814082	Compact multiprotocol I/O module for Ethernet, 8 IO-Link master channels, 4 universal digital PNP channels, 2 A, channel diagnostics, protection type IP65/IP67/IP69K

Dimension drawing	Type	ID	Description
	TBEN-L5-8IOL	6814017	Compact multiprotocol I/O module for Ethernet, 4 IO-Link master channels, 4 universal digital PNP channels, 0.5 A, channel diagnostics, protection type IP65/IP67/IP69K
	TBEN-LL-8IOL	100003910	Compact multiprotocol I/O module for Ethernet, 8 IO-Link master channels, 4 universal digital PNP channels, 2 A, channel diagnostics, protection type IP65/IP67/IP69K
	TBEN-S2-4IOL	6814024	Compact multiprotocol I/O module for Ethernet, 4 IO-Link master channels, 4 universal digital PNP channels, 0.5 A, channel diagnostics, protection type IP65/IP67/IP69K
mm [Inch]			
	RKC4.4T-2-RSC4.4T/TXL	6625608	Connection cable, M12 female connector, straight, 4-pin, M12 male connector, straight, 4-pin, cable length: 2 m, sheathing material: PUR, black; cULus approval; other cable lengths and types available, see <a href="http://www.turck.com">www.turck.com</a>
	RKC4.4T-2-TXL	6625503	Connection cable, M12 female connector, straight, 4-pin, cable length: 2 m, sheathing material: PVC, black; cULus approval; other cable lengths and types available, see <a href="http://www.turck.com">www.turck.com</a>

In addition to the above connection cables, TURCK also offers other cable types for specific applications with the correct terminals for the device. More information on this is available from the TURCK product database at [www.turck.de/products](http://www.turck.de/products) in the Connectivity area.

### 4.5.1 Mounting accessories

Dimension drawing	Type	ID	Description
<p>mm [inch]</p>	MA-M8-1/2-BSPT	100050775	Mounting adapter M8 to 1/2" BSPT
<p>mm [inch]</p>	MA-M8-1/4-NPT	100050776	Mounting adapter M8 to 1/4" NPT
<p>mm [inch]</p>	MA-M8-1/4-UNF28G	100050777	Mounting adapter M8 to 1/4" UNF 28 G
<p>mm [inch]</p>	MA-M8-3/8-24UNF2A	100050778	Mounting adapter M8 to 3/8" 24 UNF 2A

Dimension drawing	Type	ID	Description
<p>mm [inch]</p>	MA-M8-M6	100050779	Mounting adapter M8 to M6
<p>mm [inch]</p>	MA-M8-M10	100050780	Mounting adapter M8 to M10
<p>mm [inch]</p>	MA-M8-M12	100050781	Mounting adapter M8 to M12
<p>mm [inch]</p>	MA-M8-M16	100050782	Mounting adapter M8 to M16
<p>mm [inch]</p>	MA-M8-M20	100050783	Mounting adapter M8 to M20

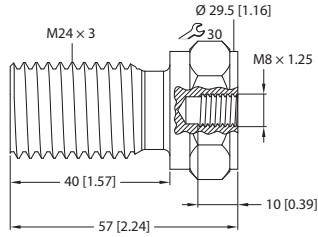
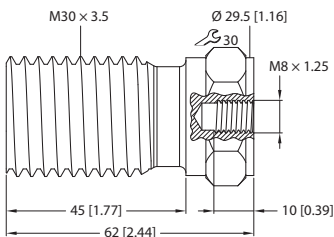
Dimension drawing	Type	ID	Description
 <p>mm [inch]</p>	MA-M8-M24	100050784	Mounting adapter M8 to M24
 <p>mm [inch]</p>	MA-M8-M30	100050785	Mounting adapter M8 to M30

## 5 Installing

The device can be installed in any alignment according to application requirements.

The measurement axis runs along the screw-in direction of the device.

- ▶ Use an M8 × 8 mm transport bore to insert the device into the mounting surface at a right angle to the axis of rotation. The measuring head surface of the device must lie flat on the mounting surface.

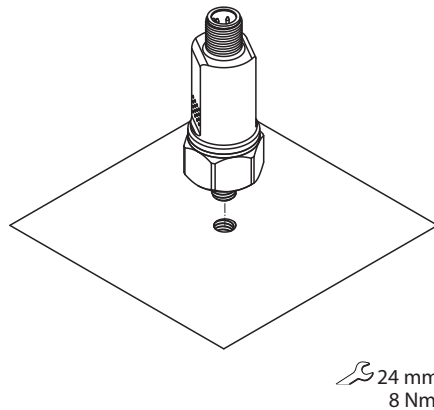

Fig. 4: Insert the sensor at a right angle.

- ▶ For other thread sizes of transport bore, use mounting adapters (not included in the scope of delivery) to secure the device.
- ▶ Screw the device into the threaded bore using a hexagon wrench (AF24) (tightening torque: 8 Nm).

## 6 Connection

- ▶ Connect the device to a controller or an I/O module as shown in "Wiring diagrams."
- ▶ Tighten the M12 connector to a tightening torque of 0.4 Nm.

### 6.1 Wiring diagrams

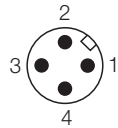

Fig. 5: Pin assignment

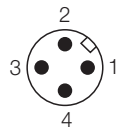

Fig. 7: Pin assignment

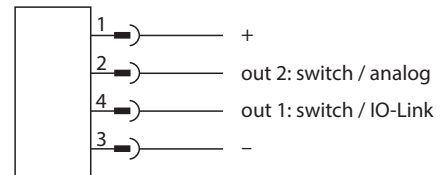

Fig. 6: Wiring diagram CMVT...-LI2IOL-...

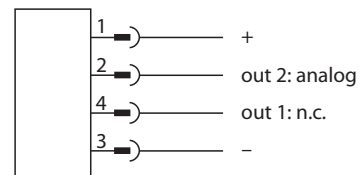

Fig. 8: Pin assignment CMVT...LI2...

## 7 Commissioning

After connecting and switching on the power supply, the device is automatically ready for operation.

## 8 Operation

The sensor transmits four measured variables (Measurement Data Channels 1...4) via process data consisting of two configurable switching signals.

Measurement Data Channel (MDC)	Switching signals
MDC 1 — vibration velocity RMS	SSC1.1 SSC1.2
MDC 2 — vibration acceleration RMS	SSC2.1 SSC2.2
MDC 3 — vibration acceleration peak	SSC3.1 SSC3.2
MDC 4 — temperature	SSC4.1 SSC4.2

The switching signals are parameterized using the following process data:

MDC	Parameters for switching signals				
	vRMS SP1	vRMS SP2	vRMS Logic	vRMS Mode	vRMS Off Delay
MDC 1 — vibration velocity RMS	0x40.1	0x40.2	0x41.1	0x42.2	0x54
MDC 2 — vibration acceleration RMS	0x44.1	0x44.2	0x45.1	0x45.2	0x56
MDC 3 — vibration acceleration peak	0x48.1	0x48.2	0x49.1	0x49.2	0x58
MDC 4 — temperature	0x52.1	0x52.2	0x53.1	0x53.2	0x60

## 9 Setting

### 9.1 Setting switching signals via Measurement Data Channels (MDC)

The following parameters can be set for Measurement Data Channels vibration velocity RMS (MDC1), vibration acceleration RMS (MDC2), vibration acceleration peak (MDC3) and temperature (MDC4):

- Switching points SP1, SP2
- Logic (high/low)
- Single Point Mode or Window Mode with a hysteresis of 2 % or freely configurable from 0...20 K for temperature

### 9.2 Setting the limit counter and timer for alarms

A limit counter and timer for limit values can be set for the Measurement Data Channels (MDC) via IO-Link. The limit values can be independent of the switching points. In addition, a pre-defined total of the amounts by which the limit values have been exceeded can be configured to trigger an alarm for a maintenance request.

The following parameters can be defined via MDC 1–4:

- Limit value
- Limit for the timer
- Limit for the limit counter

In addition, a limit for the operating hours counter can be set for the device.

A maintenance request is sent in response to the following events:

1. Limit exceeded
2. Limit counter and timer for instances where limit values are exceeded
3. Limit for limit counter and timer
4. Alarm for limit counter and timer
5. Maintenance request

### 9.3 Frequency ranges

A frequency range is selected to filter out certain measured values. The frequency ranges are parameterized via IO-Link.

Selection	Frequency range
0	10...1000 Hz
1	10...500 Hz
2	10...100 Hz
3	10...50 Hz

### 9.4 Setting and visualization with the TURCK Vibration Monitor

The device can be configured and tested with TAS (TURCK Automation Suite) or via the integrated web server of a TURCK IO-Link master (e.g. TBEN-S2-4IOL). The IODD can be read in via TAS or the web server, such that all parameters of the IODD can be accessed.

An overview of the IO-Link parameters and descriptions can be found via the **IODDfinder**. The TURCK Vibration Monitor is also available for visualizing process data.

A TURCK IO-Link master is required to access the sensor parameters and the TURCK Vibration Monitor. The following table shows the firmware version of the IO-Link master that is required to use the TURCK Vibration Monitor:

IO-Link master	Firmware version
FEN20-4IOL	V1.3.6.0
TBEN-L4-8IOL	V3.4.11.0
TBEN-L5-8IOL	V3.4.11.0
TBEN-LL-8IOL	V4.2.9.0
TBEN-S2-4IOL	V3.4.6.0

Refer to the instructions for use of the relevant device for information on the TURCK IO-Link masters.

- ▶ Connect the IO-Link master to the power supply.
- ▶ Connect the IO-Link master to a PC via the Ethernet interface.
- ▶ Connect the sensor to an IO-Link port of the IO-Link master.

#### 9.4.1 IO-Link master — opening the web server

- ▶ In order to open the web server of the IO-Link master, enter the IP address in the address bar of a local web browser (default: <http://192.168.1.254>).

A login is required on the IO-Link master in order to edit the settings via the web server and to call the TURCK Vibration Monitor.

- ▶ Enter the password in the login field on the start screen of the web server. The default password is "password".
- ▶ Click **Login**.

### 9.4.2 Reading in IODD in the web server

- ▶ Set the input port of the IO-Link master as an IO-Link port.
- ▶ Open the **IODD Configurator** tab in the web server.

**TBEN-S2-4IOL - Gateway - Info**

AIM, multiprotocol, 4 IO-Link channels

Device	
<b>Station information</b>	
Type	TBEN-S2-4IOL
Ident. no.	8814024
Firmware revision	3.3.2.0
Bootloader revision	9.0.0.0
EtherNet/IP revision	2.7.39.0
PROFINET revision	1.7.14.0
Modbus/TCP revision	2.4.2.0
WEB revision	1.1.2.0-29-ge491017
Software build number	514
Addressing mode	PGM-DHCP
<b>Special device properties</b>	
Production data	00 00 00 00 00 00 00 00 00 00 00 00

Fig. 9: Web server – IODD Configurator



## 9.5 Setting via FDT/IODD

The devices can be set via a PC with an FDT frame application (e.g. PACTware). All the required TURCK software components can be downloaded via the TURCK Software Manager:

- PACTware
- IODD
- DTM for USB-2-IOL-002 IO-Link adapter
- IODD DTM Configurator

The TURCK Software Manager can be downloaded free of charge from [www.turck.com](http://www.turck.com).

The USB-2-IOL-002 USB IO-Link adapter (ID 6825482) is required for connecting to the PC.

A 4-pin standard sensor cable (e.g. RKC4.4T-2- RSC4.4T/TXL, ID 6625608) is required for connecting the sensor to the USB-2-IOL-002 IO-Link adapter.

Further information on setting the devices via IODD with a configuration tool is provided in the IO-Link commissioning manual.

## 10 Troubleshooting

If the device does not function as expected, first check whether ambient interference is present. If there is no ambient interference present, check the connections of the device for faults.

If there are no faults, there is a device malfunction. In this case, decommission the device and replace it with a new device of the same type.

If the device does not work as expected, proceed as follows:

- ▶ Exclude environmental disturbances.
- ▶ Check the connections of the device for errors.
- ▶ Check device for parameterization errors.

If the malfunction persists, the device is faulty. In this case, decommission the device and replace it with a new device of the same type.

## 11 Maintenance

Ensure regularly that the plug connections and cables are in good condition.

The devices are maintenance-free, clean dry if required.

## 12 Repair

The device is not intended for repair by the user. The device must be decommissioned if it is faulty. Observe our return acceptance conditions when returning the device to TURCK.

### 12.1 Returning devices

If a device has to be returned, bear in mind that only devices with a decontamination declaration will be accepted. This is available for download at <https://www.turck.de/en/return-service-6079.php> and must be completely filled in, and affixed securely and weather-proof to the outside of the packaging.

## 13 Disposal



The devices must be disposed of properly and do not belong in the domestic waste.

## 14 Technical data

### 14.1 CMVT-M8T...-LI2IOL-H1141

Technical data	CMVT-M8T...-LI2IOL-H1141
ID	100050420
<b>Vibration — acceleration</b>	
Scan rate, acceleration measurement cell	23.6 kHz
RMS measuring range	10 g
RMS resolution	0.01 g
RMS repeatability	≤ ±0.5 % at 159 Hz
<b>Vibration — velocity</b>	
RMS measuring range	0...128 mm/s at 159 Hz
RMS resolution	0.01 mm/sec
RMS repeatability	≤ ±0.5 % at 159 Hz
<b>Temperature</b>	
Temperature measuring range	-40...+80 °C
Temperature linearity deviation	≤ 10 %
<b>Electrical data</b>	
Operating voltage	18...30 VDC
Residual ripple	< 10 % U <sub>ss</sub>
Communication protocol	IO-Link
Current output	4...20 mA
Load resistance, current output	≤ 0.5 kΩ
Current consumption	< 120 mA in IO-Link mode
<b>IO-Link</b>	
Communication mode	COM 2 (38.4 kBaud)
Function of pin 4	IO-Link, SIO
Function of pin 2	4...20 mA, SIO
<b>Mechanical data</b>	
Design	Cylinder, threaded
Dimensions	72.5 × 23.8 mm
Housing material	Stainless steel
Electrical connection	M12 × 1 connector
<b>Ambient conditions</b>	
Ambient temperature	-40...+80 °C
Vibration resistance (EN 60068-2-6)	20 g, 5 h/axis; 3 axes
Shock resistance (EN 60068-2-27)	60 g, 6 rms
Type of protection	IP66, IP67
MTTF	164 years acc. to SN 29500 (ed. 99) 40 °C

## 14.2 CMVT-M8T...-LI2...-H1141

Technical data	CMVT-M8T...-LI2...-H1141
<b>Electrical data</b>	
Operating voltage	18...30 VDC
Residual ripple	< 10 % U <sub>ss</sub>
Current output	4...20 mA
Load resistance, current output	≤ 0.5 kΩ
Current consumption	< 120 mA
Function of pin 2	Analog output, 4...20 mA
<b>Mechanical data</b>	
Design	Cylinder, threaded
Dimensions	72.5 × 23.8 mm
Housing material	Stainless steel
Electrical connection	M12 × 1 connector
<b>Ambient conditions</b>	
Ambient temperature	-40...+80 °C
Vibration resistance (EN 60068-2-6)	20 g, 5 h/axis; 3 axes
Shock resistance (EN 60068-2-27)	60 g, 6 rms
Type of protection	IP66, IP67
MTTF	164 years acc. to SN 29500 (ed. 99) 40 °C

## 15 TURCK branches — contact data

<b>Germany</b>	TURCK GmbH Witzlebenstraße 7, 45472 Mülheim an der Ruhr <a href="http://www.turck.de">www.turck.de</a>
<b>Australia</b>	Turck Australia Pty Ltd Building 4, 19-25 Duerdin Street, Notting Hill, 3168 Victoria <a href="http://www.turck.com.au">www.turck.com.au</a>
<b>Austria</b>	Turck GmbH Graumanngasse 7/A5-1, A-1150 Vienna <a href="http://www.turck.at">www.turck.at</a>
<b>Belgium</b>	Turck Multiprox N. V. Lion d'Orweg 12, B-9300 Aalst <a href="http://www.multiprox.be">www.multiprox.be</a>
<b>Brazil</b>	Turck do Brasil Automação Ltda. Rua Anjo Custódio Nr. 42, Jardim Anália Franco, CEP 03358-040 São Paulo <a href="http://www.turck.com.br">www.turck.com.br</a>
<b>Canada</b>	Turck Canada Inc. 140 Duffield Drive, CDN-Markham, Ontario L6G 1B5 <a href="http://www.turck.ca">www.turck.ca</a>
<b>China</b>	Turck (Tianjin) Sensor Co. Ltd. 18,4th Xinghuazhi Road, Xiqing Economic Development Area, 300381 Tianjin <a href="http://www.turck.com.cn">www.turck.com.cn</a>
<b>Czech Republic</b>	TURCK s.r.o. Na Brne 2065, CZ-500 06 Hradec Králové <a href="http://www.turck.cz">www.turck.cz</a>
<b>France</b>	TURCK BANNER S.A.S. 11 rue de Courtalin Bat C, Magny Le Hongre, F-77703 MARNE LA VALLEE Cedex 4 <a href="http://www.turckbanner.fr">www.turckbanner.fr</a>
<b>Hungary</b>	TURCK Hungary kft. Árpád fejedelem útja 26-28., Óbuda Gate, 2. em., H-1023 Budapest <a href="http://www.turck.hu">www.turck.hu</a>
<b>India</b>	TURCK India Automation Pvt. Ltd. 401-403 Aurum Avenue, Survey. No 109 /4, Near Cummins Complex, Baner-Balewadi Link Rd., 411045 Pune - Maharashtra <a href="http://www.turck.co.in">www.turck.co.in</a>
<b>Italy</b>	TURCK BANNER S.R.L. Via San Domenico 5, IT-20008 Bareggio (MI) <a href="http://www.turckbanner.it">www.turckbanner.it</a>
<b>Japan</b>	TURCK Japan Corporation ISM Akihabara 1F, 1-24-2, Taito, Taito-ku, 110-0016 Tokyo <a href="http://www.turck.jp">www.turck.jp</a>

<b>Korea</b>	Turck Korea Co, Ltd. A605, 43, Iljik-ro, Gwangmyeong-si 14353 Gyeonggi-do <a href="http://www.turck.kr">www.turck.kr</a>
<b>Malaysia</b>	Turck Banner Malaysia Sdn Bhd Unit A-23A-08, Tower A, Pinnacle Petaling Jaya, Jalan Utara C, 46200 Petaling Jaya Selangor <a href="http://www.turckbanner.my">www.turckbanner.my</a>
<b>Mexico</b>	Turck Comercial, S. de RL de CV Blvd. Campestre No. 100, Parque Industrial SERVER, C.P. 25350 Arteaga, Coahuila <a href="http://www.turck.com.mx">www.turck.com.mx</a>
<b>Netherlands</b>	Turck B. V. Ruiterlaan 7, NL-8019 BN Zwolle <a href="http://www.turck.nl">www.turck.nl</a>
<b>Poland</b>	TURCK sp.z.o.o. Wroclawska 115, PL-45-836 Opole <a href="http://www.turck.pl">www.turck.pl</a>
<b>Romania</b>	Turck Automation Romania SRL Str. Siriului nr. 6-8, Sector 1, RO-014354 Bucuresti <a href="http://www.turck.ro">www.turck.ro</a>
<b>Sweden</b>	Turck AB Fabriksstråket 9, 433 76 Jonsered <a href="http://www.turck.se">www.turck.se</a>
<b>Singapore</b>	TURCK BANNER Singapore Pte. Ltd. 25 International Business Park, #04-75/77 (West Wing) German Centre, 609916 Singapore <a href="http://www.turckbanner.sg">www.turckbanner.sg</a>
<b>South Africa</b>	Turck Banner (Pty) Ltd Boeing Road East, Bedfordview, ZA-2007 Johannesburg <a href="http://www.turckbanner.co.za">www.turckbanner.co.za</a>
<b>Turkey</b>	Turck Otomasyon Ticaret Limited Sirketi Inönü mah. Kayisdagi c., Yesil Konak Evleri No: 178, A Blok D:4, 34755 Kadiköy/ Istanbul <a href="http://www.turck.com.tr">www.turck.com.tr</a>
<b>United Kingdom</b>	TURCK BANNER LIMITED Blenheim House, Hurrricane Way, GB-SS11 8YT Wickford, Essex <a href="http://www.turckbanner.co.uk">www.turckbanner.co.uk</a>
<b>USA</b>	Turck Inc. 3000 Campus Drive, USA-MN 55441 Minneapolis <a href="http://www.turck.us">www.turck.us</a>

# TURCK

Your Global Automation Partner



Over 30 subsidiaries and  
60 representations worldwide!

100050638 | 2026/03



[www.turck.com](http://www.turck.com)